

Use and Care Manual and Installation Instructions

Electric Range

Important Safety Instructions 1-3

Use and Care

Getting to Know your Range 4
 Surface Cooking 5-6
 Using your Oven 7-11
 Using your Broiler 11
 Changing the Oven Light Bulb
 (Some Models) 12
 Care and Cleaning 13-16

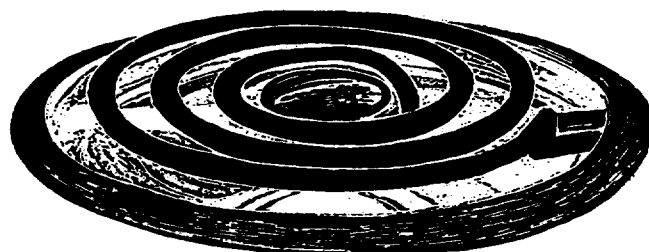

Installation Instructions

Proper Installation 17
 Mobile Home Installation 17
 Product Dimensions 18
 Parts Supplied 18
 Tools Needed 18
 Cabinet Dimensions/Requirements 19
 Electrical Requirements 20
 Installation Steps 21-23

Before You Call for Service 24

If You Need Assistance 25

Warranty 27

	<p>▲ WARNING</p>
	<ul style="list-style-type: none"> * ALL RANGES CAN TIP * INJURY TO PERSONS COULD RESULT * INSTALL ANTI-TIP DEVICE PACKED WITH RANGE * SEE INSTALLATION INSTRUCTIONS

Note to Consumer:

Please save this manual for future reference.

Note to Installer:

IMPORTANT: Please leave this manual and other literature with the consumer for future use.

IMPORTANT: Please be sure to leave these instructions for the local electrical inspector's use.

IMPORTANT SAFETY INSTRUCTIONS

READ AND SAVE THESE INSTRUCTIONS

Electric ranges have been thoroughly tested for safe and efficient operation. However, as with any appliance, there are specific installation and safety precautions which must be followed to ensure safe and satisfactory operation.

Your safety and the safety of others is very important.
We have provided many important safety messages in this manual and on your appliance. Always read and obey all safety messages.



This is the safety alert symbol.

This symbol alerts you to hazards that can kill or hurt you and others.

All safety messages will be preceded by the safety alert symbol and the word "DANGER" or "WARNING". These words mean:



You will be killed or seriously injured if you don't follow instructions.



You can be killed or seriously injured if you don't follow instructions.

All safety messages will identify the hazard, tell you how to reduce the chance of injury, and tell you what can happen if the instructions are not followed.

! WARNING

To reduce the risk of fire, electrical shock, injury to persons, or damage when using the range, follow basic precautions, including the following:

General

- Read all instructions before using the range.
- Install or locate the range only in accordance with the provided Installation Instructions. The range must be installed by a qualified installer. The range must be properly connected to electrical supply and grounded.
- Do not leave children alone or unattended in area where the range is in use. They should never be allowed to sit or stand on any part of the range. They could be burned or injured.
- Do not operate the range if it is damaged or not working properly.
- Do not use the range for warming or heating the room. Persons could be burned or injured, or a fire could start.
- Use the range only for its intended use as described in this manual.



- **WARNING:** To reduce the risk of tipping the appliance, the appliance must be secured by a properly installed anti-tip bracket. To check if the bracket is installed properly, see "The anti-tip bracket" on page 23.

- **CAUTION:** Do not store things children might want above the range. Children could be burned or injured while climbing on it.



- Do not wear loose or hanging garments when using the range. They could ignite if they touch a hot surface unit and you could be burned.

RANGE SAFETY



- Do not touch surface units, areas near surface units, heating elements, or interior surfaces of oven. Surface units and heating elements may be hot even though they are dark in color. Areas near surface units and interior surfaces of an oven become hot enough to cause burns. During and after use, do not touch or let clothing or other flammable materials contact surface units, areas near surface units, heating elements, or interior surfaces of oven until they have had sufficient time to cool. Other surfaces of the range, such as the oven vent opening, the surface near the vent opening, the cooktop, and the oven door and window, could also become hot enough to cause burns.
- Use only dry pot holders. Moist or damp pot holders on hot surfaces could result in burns from steam. Do not let pot holder touch hot heating elements. Do not use a towel or bulky cloth for a pot holder. It could catch on fire.
- Keep range vents unobstructed.
- Do not heat unopened containers. They could explode. The hot contents could cause burns and container particles could cause injury.
- Use only cookware approved for oven use. Follow cookware manufacturer's instructions, especially when using glass or plastic cookware.
- Do not store flammable materials on or near the range. The fumes could create an explosion and/or fire hazard.

When using the cooktop

- Make sure the reflector bowls are in place during cooking. Cooking without reflector bowls could subject the wiring and components underneath them to damage.
- Do not line reflector bowls with aluminum foil or other liners. Improper installation of these liners could result in a risk of electric shock or fire.
- Select a pan with a flat bottom that is about the same size as the surface unit. If pan is smaller than the surface unit, some of the heating element will be exposed and could result in the igniting of clothing or pot holders. Correct pan size also improves cooking efficiency.
- Check to be sure glass cookware is safe for use on the range. Only certain types of glass, glass-ceramic, ceramic, earthenware, or other glazed cookware are suitable for cooktops without breaking due to the sudden change in temperature.
- Never leave surface units unattended at high heat settings. A boilover could result and cause smoking and greasy spillovers that could ignite.



- Turn pan handles inward, but not over other surface units. This will help reduce the chance of burns, igniting of flammable materials, and spills due to bumping of the pan.
- Should food flame when cooking under a ventilating hood, turn the hood on.

RANGE SAFETY

When using the oven

- Always position oven rack(s) in desired location while oven is cool. If a rack must be removed while oven is hot, do not let pot holder contact hot heating elements in oven.
- Use care when opening oven door. Let hot air or steam escape before removing or replacing food.

Grease

- Grease is flammable. Do not allow grease to collect around cooktop or in vents. Wipe spillovers immediately.



- Do not use water on grease fires. Never pick up a flaming pan. Smother flaming pan on range by covering with a well-fitting lid, cookie sheet, or flat tray. Flaming grease outside of pan can be extinguished with baking soda or, if available, a multipurpose dry chemical or foam-type extinguisher.

Care and cleaning

- Do not soak removable heating elements in water. The element will be damaged and shock or fire could result.
- Clean only parts recommended in this Use and Care Guide.
- Do not repair or replace any part of the range unless specifically recommended in this manual. All other servicing should be referred to a qualified technician.
- Disconnect the electrical supply before servicing the range.

GETTING TO KNOW YOUR RANGE

This section contains captioned pictures of your range. Use them to learn where all parts and features are and what they look like. Use the page references to help you quickly find out more about the part or feature you are interested in.

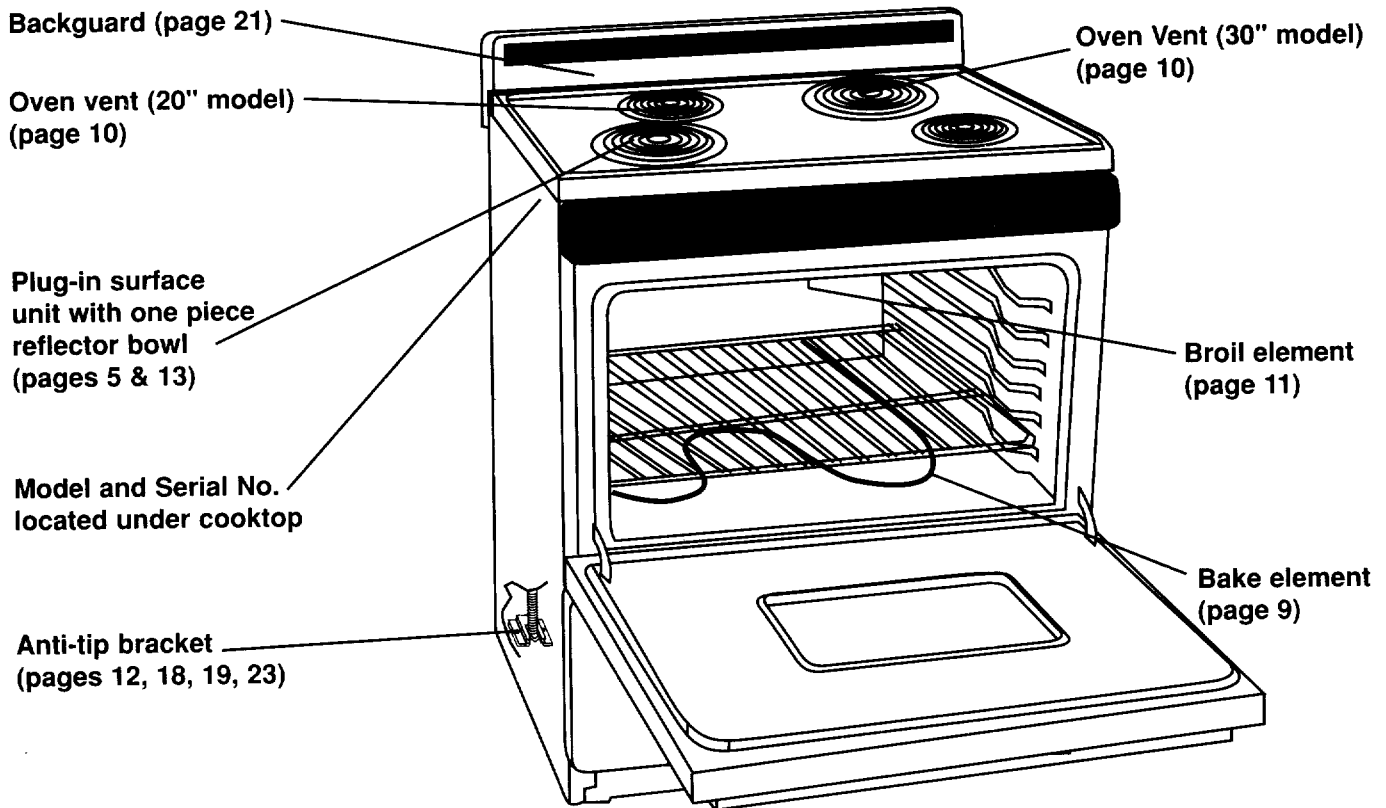

Control panel

(See page 5 for more information)

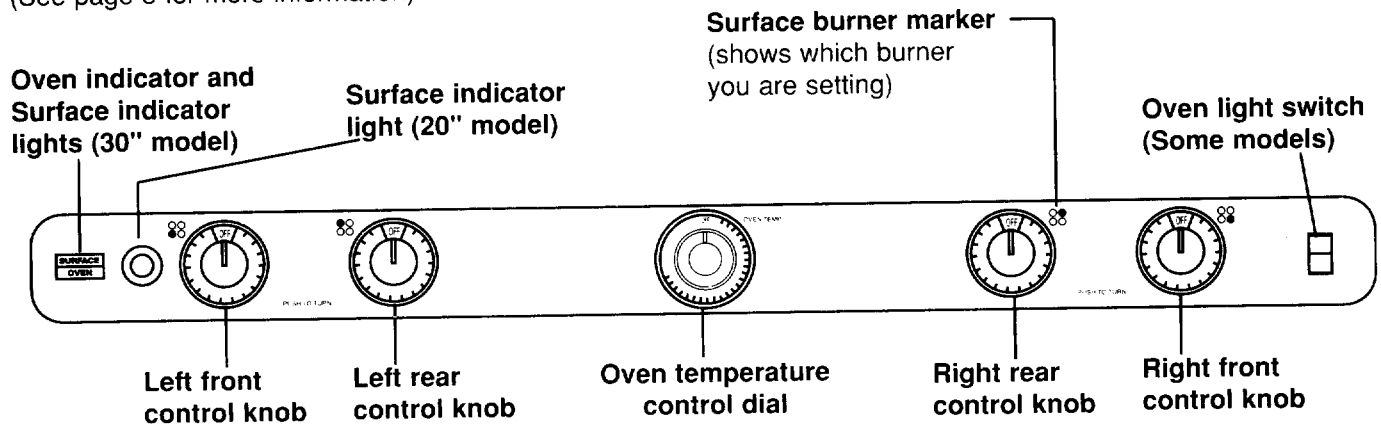

USING THE SURFACE UNITS

Using the control knobs

Push in the control knobs before turning them to a setting. You can set them anywhere between HI and OFF. The controls do not have to be set exactly on a marked setting. Use the marks as a guide and adjust the control as needed.

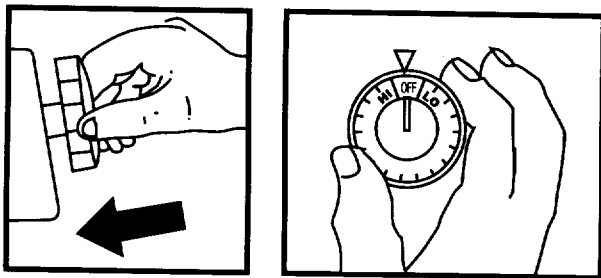

Surface unit heat settings

Use the following chart as a guide.

SETTING	RECOMMENDED USE
HI	To start foods cooking. To bring liquids to a boil.
5-6	To hold a rapid boil. To fry chicken or pancakes.
4	For gravy, pudding, and icing. To cook large amounts of vegetables.
2-3	To keep food cooking after starting it on a higher setting.
LO	To maintain a simmer. To keep food warm until it's ready to serve.

! WARNING



Fire Hazard

**Turn all controls off when done cooking.
Failure to do so can result in death, fire,
or burns.**

Easy ways to save energy

- Match the pan to the surface unit size. The pan should have a flat bottom, straight sides, and a tight-fitting lid.
- To help shorten your cooking time, use the least amount of liquid possible.
- Preheat your pans only when recommended and for the shortest time possible.
- Start your food on a higher heat setting, then turn the control to a lower setting to finish cooking.
- Place a filled pan on the surface unit before turning on the surface unit.
- Keep your reflector bowls clean for best heat reflection.

Surface indicator lights

The Surface Indicator Light will be on whenever any of the surface elements are on. Be sure to check this light when you have finished all cooking operations.

20" MODEL

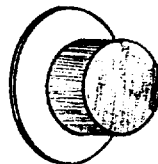

30" MODEL

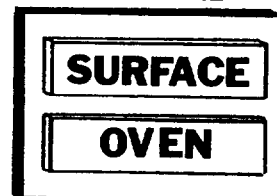

USING THE SURFACE UNITS

Using cookware

- Use the correct cookware to prevent damage to the surface unit, cooktop, wiring, and surrounding areas.
- If the cookware is too small for the surface unit or the bottom is not flat, the surface unit could stay glowing red for an extended length of time causing damage to the unit.
- If you start cooking on high, it is important to turn the control down to a lower setting to complete cooking.
- The surface unit could overheat or be damaged if a pot has boiled dry or has been left empty on a hot surface unit.

Using the right cookware makes a big difference

- Flat bottomed cookware, including woks, canners, and teakettles, will provide better contact with the surface unit and provide the best cooking and energy saving results.
- Warped, dented, and ribbed-bottomed cookware can result in uneven cooking due to incomplete contact with the surface unit.
- Cookware that has been designed with slightly indented bottoms or small expansion channels can be used.
- Choose medium to heavy gauge (thickness) cookware.
- The pan material (type of metal or glass) affects how quickly and evenly the pan heats.

Home canning information

To protect your range:

- Use flat-bottomed canners/pans for best results.
- Use the largest surface unit for best results. Also, use a canner/pan that you can center over the surface. Large diameter canners/pans, if not centered correctly, trap heat and can cause damage to the cooktop.
- Do not place your canner on two surface

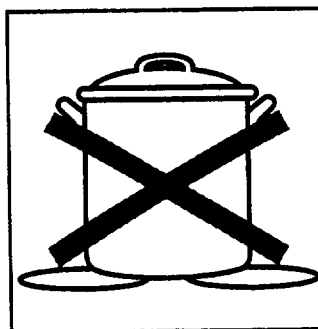

units at the same time. Too much heat will build up and will damage the cooktop.

- Start with hot water. This reduces the time the control is set on high. Reduce

the heat setting to the lowest position needed to keep water boiling.

- Keep your reflector bowls clean so that they will always reflect heat well.
- To keep your elements working for as long as possible:
 - Prepare small batches at a time.
 - Do not use your elements for canning all day.
- Refer to your canner manual for specific instructions.

USING YOUR OVEN

Oven control

Your oven temperature is controlled very accurately using an electric oven control system. We recommend that you operate the oven for a number of weeks to become familiar with your new oven's performance.

To use your oven, turn the oven control dial clockwise to the desired temperature. **DO NOT TURN TO THE BROIL SETTING AND THEN BACK TO THE DESIRED TEMPERATURE.** When the control is turned on, the bake element turns on to full power until the set temperature is reached, then temperature is maintained by the bottom element cycling on and off.

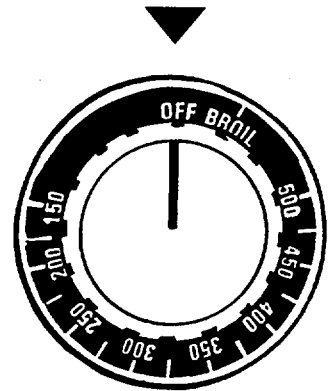

Oven indicator light (30" model only)

The Oven Indicator Light will go on when the control is turned on. As the oven heat reaches the selected temperature, the light goes off. As the oven element turns on and off to maintain the selected temperature during the cooking operation, the red indicator light will go off and on.

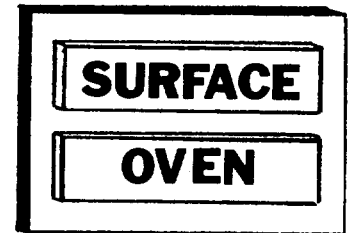

Initial oven operation

Slight odor or smoke from the insulation around the oven liner is normal for the first few times the oven is used.

Preheat

The oven should be preheated for most baked products (cakes, pies, bread, etc....) or when using temperatures below 225°F. Time and temperature suggestions in most cookbooks are for preheated ovens. Preheat oven by rotating the temperature control dial to the temperature needed for the product being cooked. Allow 10 to 12 minutes before putting food in the oven.

USING YOUR OVEN

Positioning rack(s) and pans

The racks are designed with stop locks. When placed correctly on the rack supports, they will stop before coming completely out of the oven and will not tilt when you are removing food from them or placing food on them.

To remove a rack from the oven, pull it toward you, tilt the front end upward, and pull it out.

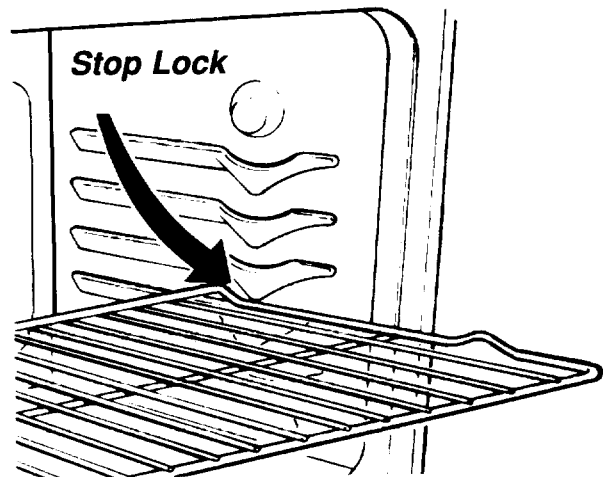

General guidelines

Follow this section to get the best cooking results.

- Always place oven racks where you need them before turning on the oven.
- To move a rack, pull it out to the stop, raise the front edge, and lift it out.
- Be sure the rack(s) is level.
- If rack(s) must be moved while the oven is hot, use pot holders or oven mitts to protect your hands.
- When baking/roasting with 1 rack, place the rack so the top of the food will be centered in the oven.
- Do not place items on the oven door when it is open.

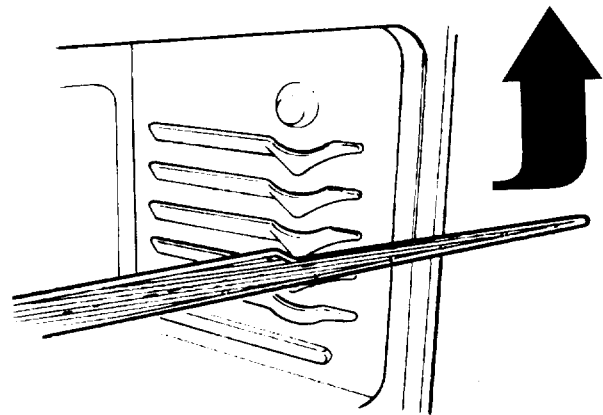

NOTE: For information on where to place your racks when broiling, see “Broiling chart” on page 11.

BAKING TIPS:

When baking with insulated cookie sheets or baking pans, place them in the bottom third of the oven. You may need to increase the recommended baking times, so test for doneness before removing from the oven.

For most baking, reduce the oven temperature by 25°F but use the same baking time when using ovenproof glassware or dark pans. These pans absorb heat.

Rack placement for specific foods:

FOOD	RACK POSITION
Frozen pies, large roasts, turkeys, angel food cakes	1st or 2nd rack guide from bottom
Bundt cakes, most quick breads, yeast breads, casseroles, meats	2nd rack guide from bottom
Cookies, biscuits, muffins, cakes, nonfrozen pies	2nd or 3rd rack guide from bottom

USING YOUR OVEN

For best air circulation

Hot air must circulate around the pans in the oven for even heat to reach all parts of the oven. This results in better baking.

- Place the pans so that one is not directly over the other.
- For best results, allow 1-1/2 to 2 inches (4-5 cm.) of space around each pan and between pans and oven walls.
- Use only one cookie sheet in the oven at a time.

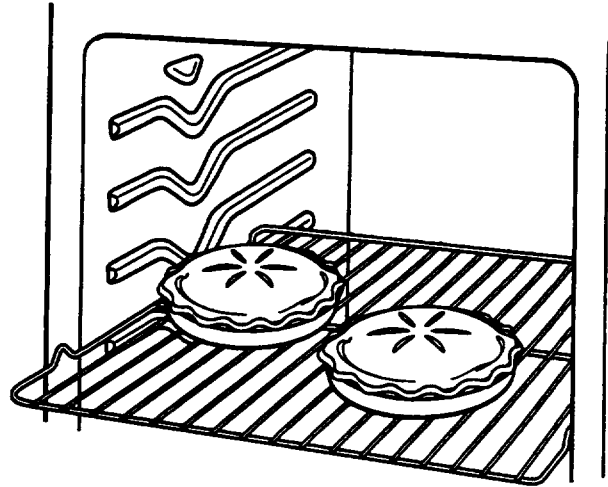

Use the following as a guide to determine where to place the pans:

One pan

Place in the center of the oven rack.

Two pans

Place in opposite corners of the oven rack or on two separate racks.

Three or four pans

Place in opposite corners on each oven rack. Stagger pans so no pan is directly over another.

Baking

Your new oven may heat differently than your old oven. The times and temperatures to which you have been accustomed may vary slightly because of these differences.

BAKING HINTS

1. Always follow the package instructions or a reliable recipe. Use the recommended pan size. Cooking times may vary in high altitude areas.
2. Baking results will be better if pans are centered as much as possible. For best results, bake only one pan at a time. Pan should be placed so top of food is centered in the oven. Bake food for minimum recommended time or until food is done and properly browned.
3. Do not place large cookie sheets or pans on a rack in the bottom position. Doing so will block air circulation and may cause the oven to heat improperly.
4. For 30" ranges, when two cakes or pies are baked at the same time, place both pans on the same rack, using the second rack position from the bottom. When four cakes or pies are baked at the same time, place two pans on each rack, using the second and fourth rack positions from the bottom.

For 20" ranges, bake only one cake at a time.

USING YOUR OVEN

Using aluminum foil for baking

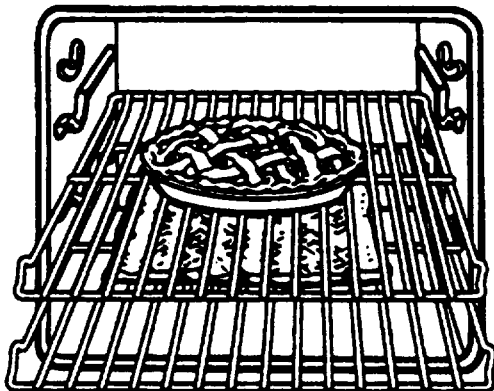

Use aluminum foil to catch spillovers from pies and casseroles:

Models with two oven racks:

Place the foil on the oven rack below the rack with the food. Turn up foil edges and make sure foil is about 1 inch (3 cm.) larger all around than the dish holding the food.

Models with one oven rack:

Place the foil directly under the dish holding the food. Turn up foil edges and make sure foil is about 1 inch (3 cm.) larger all around than the dish holding the food.

- Do not cover the entire rack with aluminum foil. It will reduce air circulation and cause poor cooking results.
- Do not line oven bottom with foil or other liners. It could affect the quality of your baking.

The oven vent

Hot air and moisture escape from the oven through a vent under one of the rear surface units. You can cook on this unit or keep food warm on it while the oven is on. The vent is needed for air circulation. **Do not block the vent by using extra large pans or covers.** You will get poor baking/roasting results.

⚠ WARNING

Fire Hazard
Use pot holders to move utensils left on the rear surface units.
Keep flammable materials away from the oven vent.
Failure to follow these precautions can result in death, fire, or burns.

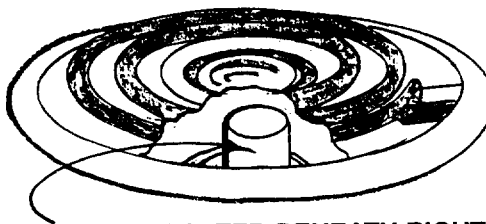
OVEN VENT



VENT LOCATED BENEATH RIGHT REAR SURFACE UNIT ON 30" MODEL
VENT LOCATED BENEATH LEFT REAR SURFACE UNIT ON 20" MODEL

IMPORTANT: Never store plastics, paper, or other items that could melt or burn near the oven vent, or any of the surface units.

USING YOUR OVEN

Roasting

Roasting is oven cooking of tender cuts of meat and poultry. Low temperature roasting cooks meat to an appetizing brown with out undue loss of juices and minimum shrinkage. It also reduces spattering and keeps oven cleanup to a minimum.

FOR BEST RESULTS:

1. Check weight of meat and place, fat side up, on roasting rack in a shallow pan.
2. Place on oven rack in middle or lower position. Close oven door.
3. Set oven control at 325°F.
4. Follow time suggested on the roasting chart in your favorite cookbook. These times are only a guide as meat cuts will differ. A meat thermometer is the only accurate test for doneness.

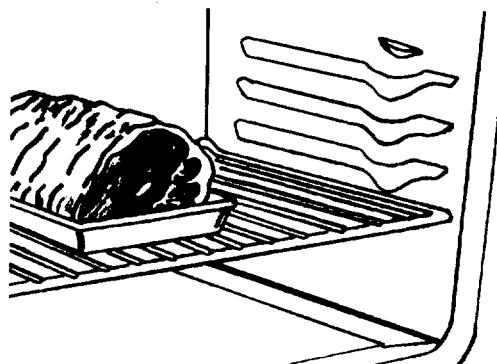

Broiling

Broiling is a fast method for cooking tender cuts of meats, poultry, ham and fish.

Your range is equipped with a variable broil feature which allows you to broil at temperatures from the **BROIL** setting down to 350°F. Broil with the door closed, for a cleaner, cooler kitchen. The smoke from broiling is consumed as it is drawn over a rod-type broil element.

Turn the oven control dial clockwise to **BROIL** for a full broil. **TO SET AT TEMPERATURES BELOW FULL BROIL, TURN TO BROIL AND THEN BACK TO THE DESIRED SETTING.** For broiling do not turn the oven control dial below 350°F. After broiling, the dial must be turned to **OFF** before baking.

BROILING CHART				
Food	Rack Position	Broil Temperature	Cooking Time	
			First Side	Second Side
Steaks - 1" thick Medium Well Done	2nd from top Lowest or 2nd Lowest	Broil 425°F	6 to 8 min. 12 to 14 min.	5 to 7 min. 10 to 12 min.
Ground beef patties - 1/2" thick Well Done	2nd or 3rd from top	425°F	10 to 12 min.	6 to 8 min.
Chicken	Lowest	425°F	30 to 35 min total cooking time. Turn frequently.	
Fish	Lowest	425°F	22 to 30 min total cooking time. Turn whole fish once. Do not turn fillets.	

Cooking times given are approximate and should be used only as a guide. Variables in meats and personal preferences may make changes necessary.

USING YOUR OVEN

Oven light (optional on some models)

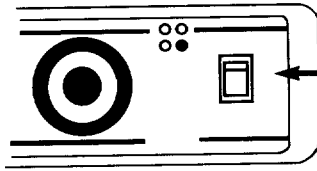

OVEN LIGHT SWITCH

The switch located at the right of the control panel turns the oven light on and off.

Changing the oven light bulb

1. Gloves must be worn to protect your hands when changing the bulb.
2. Disconnect the power to the range at the main circuit breaker.
3. Make sure the oven is cool before replacing the light bulb.
4. Unscrew the light bulb counterclockwise.
5. Replace the bulb with a 40-watt appliance bulb.
6. Reconnect the power to the range.

The anti-tip bracket

The range will not tip during normal use. However, the range can tip if you apply too much force or weight to the open door without the anti-tip bracket fastened down properly.

A stick figure is shown pushing against the base of a range that is tipping over. The range is tilted at a steep angle.	<p>⚠ WARNING</p> <p>Tip Over Hazard</p> <p>A child or adult can tip the range and be killed. Connect anti-tip bracket to rear range foot. Reconnect the anti-tip bracket, if the range is moved. See the installation instructions for details.</p> <p>Failure to follow these instructions can result in death or serious burns to children and adults.</p>
<p>Anti-Tip Bracket</p> A diagram showing a metal bracket with a threaded hole. A screw is being inserted into the hole. An arrow points to the bracket, and another arrow points to the screw. The text 'Range Foot' is written below the screw. <p>Range Foot</p>	<p>Making sure the anti-tip bracket is installed:</p> <ul style="list-style-type: none">• Slide range forward.• Look for the anti-tip bracket securely attached to floor.• Slide range back so rear range foot is under anti-tip bracket.

CARE AND CLEANING

Your range is designed so you can care for it easily. You can do most cleaning with items found around your home. Cleaning your range whenever spills or soiling occurs will help to keep it looking like new.

	<p style="text-align: center;">⚠ WARNING</p> <p style="text-align: center;">Electrical Shock Hazard</p> <p>Make sure all controls are off and the range is cool before cleaning. Failure to do so can result in death, electrical shock, or burns.</p>
---	---

Cleaning porcelain oven

Porcelain has a smooth finish, and is a type of glass fused to metal. With proper care, the porcelain enamel walls in this oven will retain a good looking finish for many years.

Food soil that is allowed to harden and bake on can be difficult to remove.

Clean the oven before it is entirely cool (not while it is hot) with detergent and water - using a soap-filled steel wool pad on burned spots. Rinse and wipe dry.

Commercial oven cleaners may be used on conventional porcelain lined ovens. **Do not spray any oven cleaners on the electrical elements, controls, or switches because it could cause a short circuit and result in sparking or fire. Do not let commercial oven cleaners contact the heat seals or exterior surfaces of the range. This will cause damage.** Follow instructions carefully. After using cleaners, thoroughly rinse the oven with a solution of one tablespoon vinegar to one cup water. Oven cleaners can coat or damage the thermostat -sensing device (long tube in oven) so that it will not sense temperature correctly. If you are using a commercial oven cleaner, try to avoid any contact with the rod-shaped bulb of the thermostat. Be sure that any residue that touches the bulb is carefully removed.

Oven racks are removed by pulling forward, tilting and lifting up. Racks may be washed with detergent and water. Scour heavily soiled areas with a soap-filled steel wool pad.

Oven and surface heating elements

Both the oven and the surface heating elements clean themselves when they are turned on. Food spilled on a hot element will burn off. **Do not immerse the surface elements in water.**

TO REMOVE SURFACE ELEMENTS:

Surface elements can be removed to make cleaning easier. **To avoid the possibility of a burn or electric shock, always be certain that the controls for all surface units are at the "OFF" position and all coils are cool before attempting to lift or remove a surface unit.** To remove, lift up edge of element opposite terminal and pull out to clear the reflector pans.

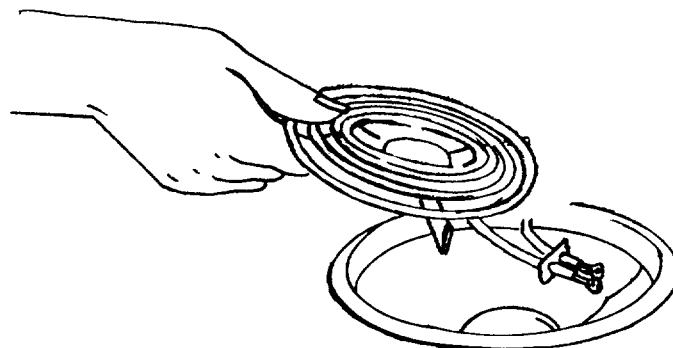

CARE AND CLEANING

Reflector pans

Wash reflector pans in warm, sudsy water or in the dishwasher. Rinse and dry while still warm. Hard-to-remove soil can be removed using a nylon scrubber and a mild detergent and water. **DO NOT USE STEEL WOOL.**

TO REMOVE REFLECTOR PANS:

The chrome heat reflector pans are removed by first removing the element, (See: To Remove Surface Elements page 13) and then lifting the reflector pan out.

Control knobs and dials

Clean up any spills or splatters on the knobs and dial with a damp cloth. Remove heavier soil with soapy water. The control knobs and dial may be removed for easier cleaning by pulling straight off the stem. Wash the knobs in soap and water but do not soak.

Oven bottom

The oven bottom is not removable. To clean the oven bottom surface, the oven element can be lifted to allow for cleaning beneath the element.

To avoid the possibility of a burn or electric shock, when cleaning the oven section make sure the bake and broil elements are “OFF” and cool. Even though they are dark in color, they may be still warm enough to cause a burn.

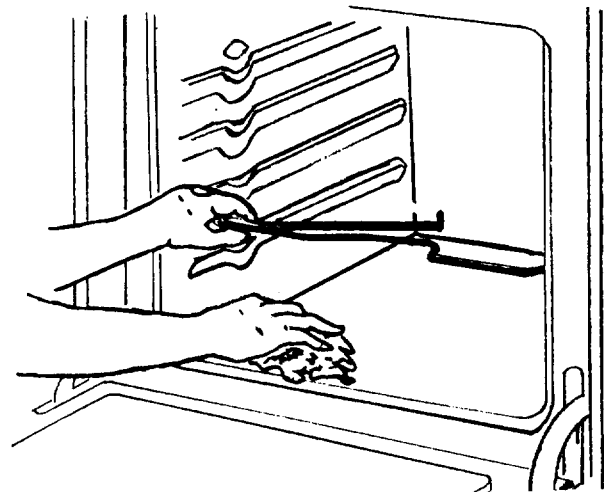

Broiler pan and tray

Clean using warm, sudsy water, a mildly abrasive cleaner, a soap filled abrasive pad or commercial oven cleaner, following the manufacturer's instructions.

CARE AND CLEANING

Cleaning porcelain cooktop, oven door, and storage outer panel

Wash with a sponge and warm soapy water. Wipe with clean water and dry well.

Use a nonabrasive plastic scrubbing pad on heavily soiled areas.

Do not use abrasive or harsh cleaners, (such as chlorine bleach, ammonia, or commercial oven cleaners) which can damage the finish.

LIFT-UP COOKTOP:

To make cleaning easier, the entire cooktop may be lifted up and supported in the up position. **To avoid the possibility of a burn or electrical shock, make sure all the surface units are turned "OFF" and cool before raising the top.**

The recessed area beneath the lift-up cooktop may be wiped clean with a warm soapy rag.

- Do not use gritty or harsh cleaners, which can damage the finish of the recessed area beneath the cooktop.

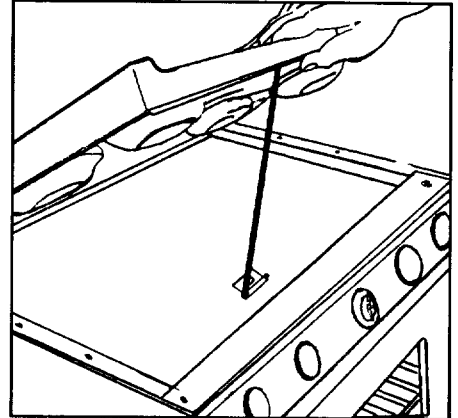

TO REMOVE OVEN DOOR:

The 20" range door can not be removed.
The 30" range has a lift-off door.

To remove lift-off door:

1. Open oven door approximately three inches to its self stop position.
2. Grasp oven door firmly on both sides and lift complete door straight up and off hinge assembly.

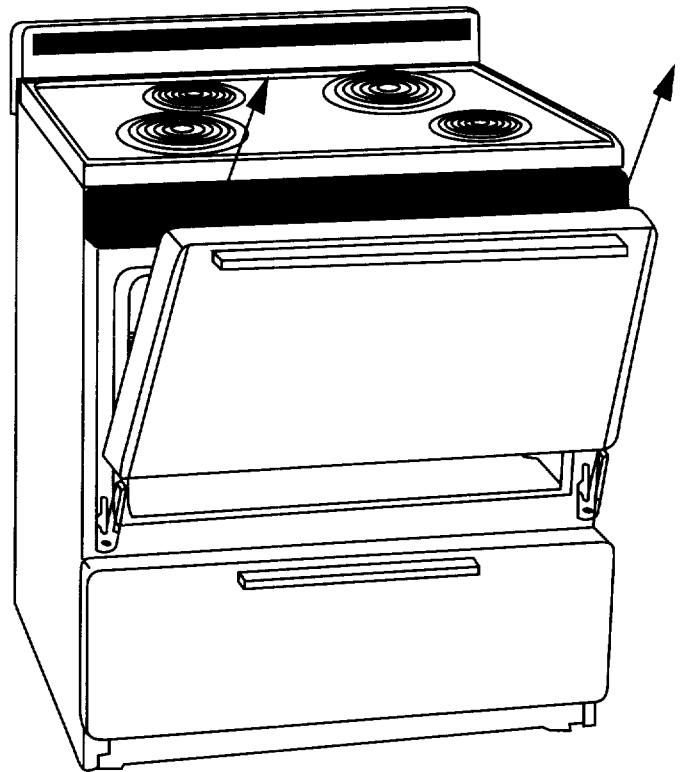

CARE AND CLEANING

TO REMOVE STORAGE DRAWER (optional on some models):

The storage drawer can be removed for easier cleaning. The storage drawer may be wiped clean with a warm soapy rag.

- Do not use harsh cleaners, steel wool, or gritty cleansers, which can damage the finish of the drawer.

To remove drawer:

1. Pull drawer out to the stop position.
2. Push up under the center of the drawer while pulling the drawer out to allow the drawer stop to clear the range front frame.
3. Drawer will slide free of range.

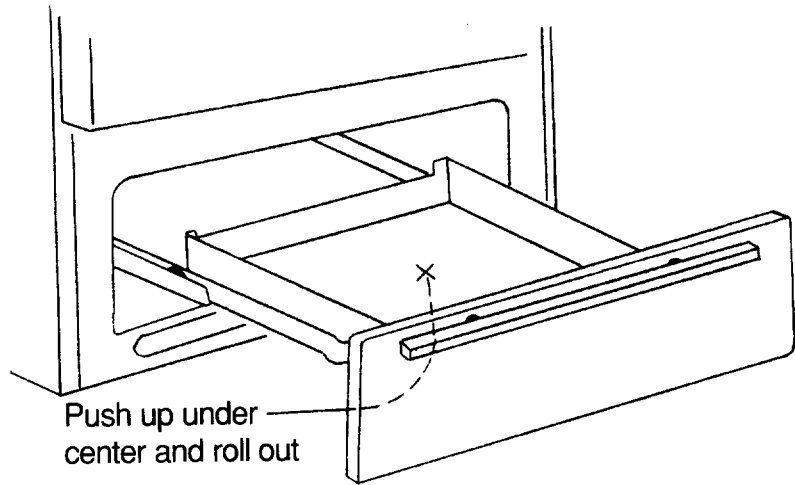

To replace drawer:

1. Slide drawer back in on tracks until the drawer stop hits range front.
2. Push up under center of drawer while sliding drawer in.

BEFORE YOU START INSTALLING

IMPORTANT NOTE TO INSTALLER

BEFORE YOU BEGIN - DISCONNECT THE POWER TO THE RANGE AT THE MAIN CIRCUIT BREAKER AND READ THESE INSTRUCTIONS COMPLETELY AND CAREFULLY.

SAVE THESE INSTRUCTIONS FOR THE LOCAL ELECTRICAL INSPECTOR'S USE.

Important: Observe all governing codes and ordinances.

Proper installation is your responsibility. A qualified technician must install this range. Make sure you have everything necessary for correct installation. It is the installer's responsibility to comply with installation clearances specified in these instructions and the electrical requirements specified on the model/serial rating plate located under the cooktop.

Check location where range will be installed. The range should be located for convenient use in kitchen.

Cabinet opening dimensions shown on page 19 must be used. Given dimensions are minimum clearances.

Grounded electrical outlet is required. See "Electrical requirements," Page 20.

It is the customer's responsibility to contact a qualified electrical installer and to make sure that the electrical installation is adequate and in conformance with National Electrical Code, ANSI/NFPA 70 - latest edition*, and all local codes and ordinances.

CLEARANCES - When installing a range around cabinets, use the recommended clearances given in Table X, page 19, and the maximum and minimum clearances description given on page 19 in order to conform with safety standards.

The maximum depth of cabinets installed above cooking tops is **13 inches**.

The sides of the range can be flush to combustible material below the cooktop. The back of the range can be flush to combustible material. Zero clearance is permitted between the range and combustible construction extending from the cooking surface to **18 inches** above the level of the cooking surface.

IMPORTANT: Serious hazards are associated with reaching into storage cabinets above a range. To eliminate the risk of burns or fire by reaching over heated surface units, avoid locating cabinet storage space above the surface units. If storage cabinet is provided above a range with a lower oven only, the hazard can be reduced by installing a range hood that projects horizontally a minimum of 5 inches beyond the bottom of the cabinet.

Caution: Not all cabinets and building materials are designed to withstand the heat produced during the normal safe operation of a listed appliance. Damage, such as discoloration or delamination may occur.

Mobile home installation

The installation of this range must conform with the Manufactured Home Construction and Safety Standard, Title 24 CFR, Part 3280 (formerly the Federal Standard for Mobile Home Construction and Safety, Title 24, HUD (Part 280)) or, when such standard is not applicable, the Standard for Manufactured Home Installations, ANSI A 225.1/NFPA 501A, or with local codes.

When this range is installed in a mobile home, it must be secured to the floor during transit. Any method of securing the range is adequate as long as it conforms to the standards listed above.

Four wire power supply cord or cable must be used in a mobile home installation. The appliance wiring will need to be revised. See "Four-wire electrical connection." Page 22.

Copies of the standards may be obtained from:

***National Fire Protection Association
Batterymarch Park
Quincy, Massachusetts 02269**

BEFORE YOU START INSTALLING

Product dimensions

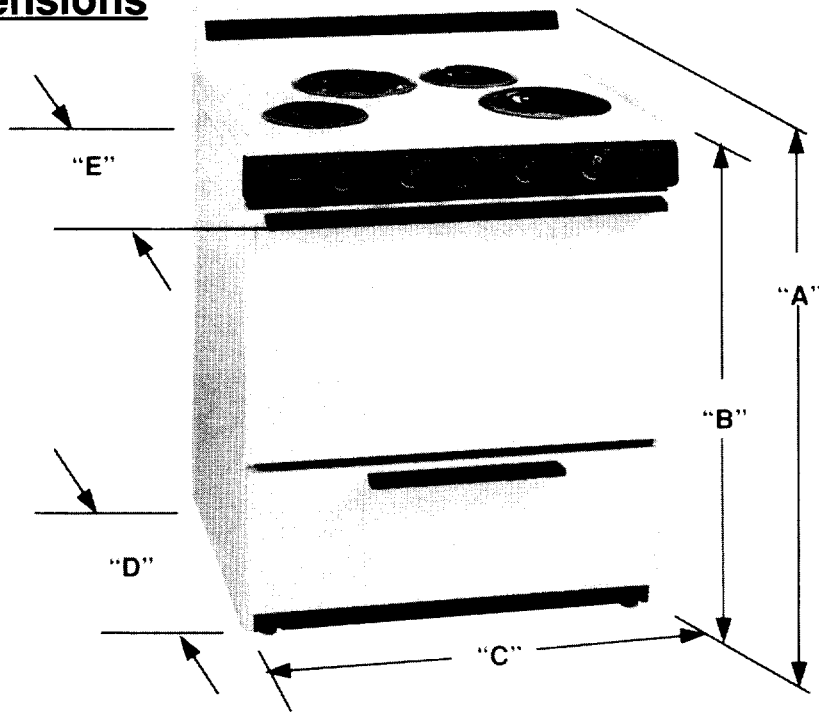

MODEL	OVERALL HEIGHT DIM. "A"	COOKTOP HEIGHT DIM. "B"	WIDTH DIM. "C"	DEPTH WITHOUT HANDLE DIM. "D"	DEPTH WITH HANDLE DIM. "E"
30" ELECTRIC	40"	36"	30"	26"	27 1/8"
20" ELECTRIC	40"	36 1/4"	20 3/16"	24 1/2"	25 1/2"

Parts supplied:

Tools needed:

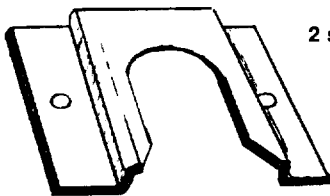

2 screws #10 x 1"



floor-mounted anti-tip bracket

Not shown:
*literature pack

Bracket must be securely mounted to sub-floor. Thickness of flooring may require longer screws to anchor bracket to sub-floor. Longer screws are available from your local hardware store.



Phillips screwdriver

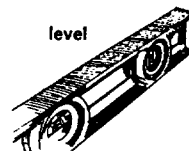

level

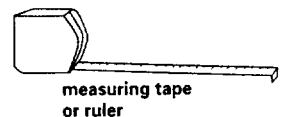

measuring tape or ruler



3/8" nut driver

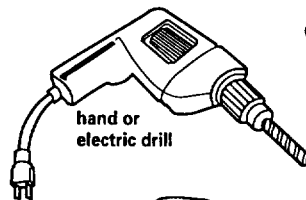

hand or electric drill



wood floors:
1/8" drill bit

concrete/ceramic floors:
3/16" carbide-tipped masonry drill bit (Hammer may be needed for anchors.)



safety glasses



gloves



channel lock pliers

BEFORE YOU START INSTALLING

Cabinet dimensions/requirements

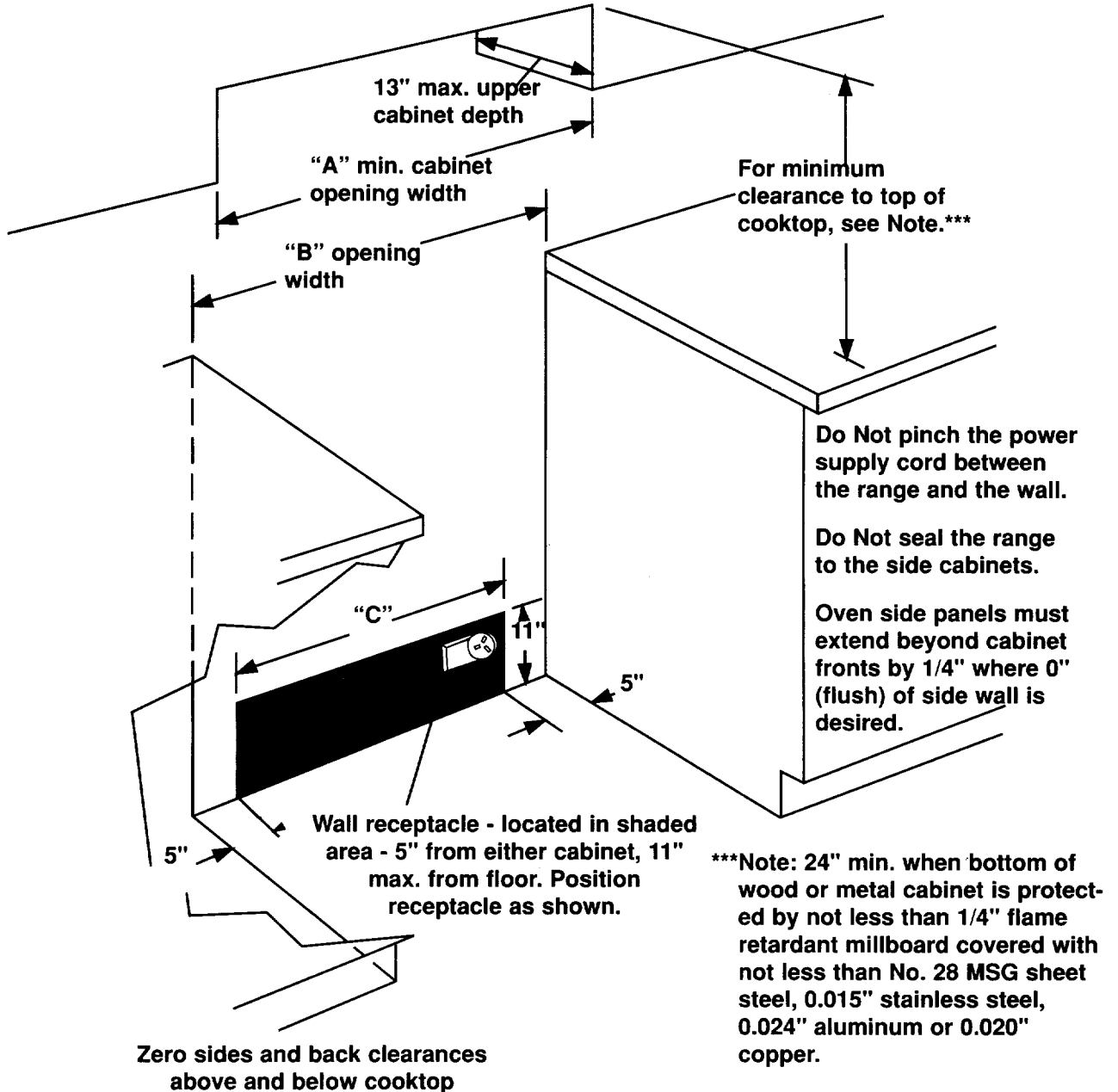

TABLE X

MODEL	DIM. "A"	DIM. "B"	DIM. "C"
20"	20"	20 1/4"	10 1/4"
30"	30"	30 3/16"	20 3/16"

Anti-tip bracket

The floor-mounted anti-tip bracket **MUST** be installed. To install the anti-tip bracket supplied, see Page 23 and the anti-tip bracket template/instruction sheet.

BEFORE YOU START INSTALLING

Electrical requirements

⚠ WARNING



Electrical Shock Hazard

Electrically ground this range.
Failure to ground can result in death or electrical shock.

Do not ground to a gas pipe.

Check with a qualified electrician if you are not sure the range is properly grounded.

If codes permit and a separate grounding wire is used, it is recommended that a qualified electrician determine that the grounding path is adequate.

Power supply cord is not supplied, but is available through your local electrical supply house.

Range must be connected to the proper electrical voltage and frequency as specified on the model/serial rating plate. (The model/serial rating plate is located under the cooktop).

- CONNECT WITH COPPER WIRE ONLY.**
- A three-wire or 4-wire, single-phase, 120/240-volt, 60-Hz, AC-only, electrical supply (or three-wire or four-wire 120/208 volt if specified on the model/serial rating plate) is required on a separate, 40-ampere circuit, fused on both sides of the line.
- A time-delay fuse or circuit breaker is recommended.
- Local codes may permit the use of a U.L.-listed, 250-volt, 40-ampere range power supply cord (pigtail). This cord contains three, No.-10 copper wires and matches a three-wire receptacle of NEMA Type 10-50R, shown in Figure 1. Connectors on the appliance end must be provided at the point the power supply cord enters the appliance.

- The range can be connected directly to the fused disconnect (or circuit breaker box) through flexible, armored or non-metallic sheathed, copper cable (with grounding wire). Allow two to three feet of slack in the line so that it can be moved if servicing is ever necessary.

A U.L. listed conduit connector must be provided at each end of the power supply cable (at the range and at the junction box).

Wire sizes (COPPER WIRE ONLY) and connections must conform with the rating of the range (40-amperes).

- The wiring diagram** is located on the back of the range.

If connecting to a four wire system:

This range is manufactured with the ground connected to the cabinet. This ground must be revised so the green grounding wire of the four-wire power supply cord is connected to the cabinet. See "Special grounding instructions for 4-wire system" section, Page 22.

When a four-wire receptacle of NEMA Type 14-50R is used (see Figure 2), a matching U.L.-listed, four-wire, 250-volt, 40-ampere, range power supply cord (pigtail) must be used. This cord contains four copper conductors with ring terminals at the appliance end, terminating in a NEMA Type 14-50P plug on the supply end. The fourth (grounding) conductor must be identified by a green or green/yellow cover and the neutral conductor by a white cover. Cord should be Type SRD or SRDT with a U.L. listed strain relief and be at least four feet long.

The **MINIMUM** conductor sizes for the copper four-wire power cord are:

- 40-ampere circuit
- 2, No.-8 conductors
- 1, No.-10 white neutral
- 1, No.-8 green grounding

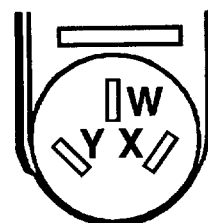

3-wire wall receptacle (10-50R)

Figure 1

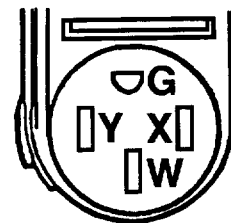

4-wire wall receptacle (14-50R)

Figure 2

INSTALLATION STEPS

Remove oven racks and parts package from inside oven. Remove shipping materials, tape and protective film from range.

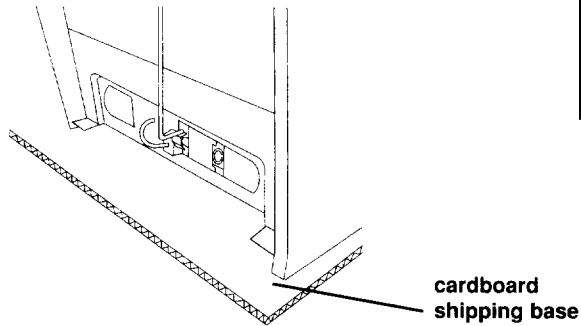

Keep cardboard shipping base under range to prevent damage to floor coverings.

⚠ WARNING

Excessive Weight Hazard

Use two or more people to move and install the range. Failure to do so can result in back or other injury.

Porcelain backguard installation

1. Move range cooktop forward about two inches and position backguard over the backguard support.
2. Attach backguard to backguard support with (4) (A) wing nuts. **A** 
3. On the front of the backguard, two nuts are provided on the threaded hinge pin. Remove these two nuts. Place the cooktop on the pins. Lift the front of the cooktop and thread the two nuts on the hinge pins. Push the cooktop down into the normal position.

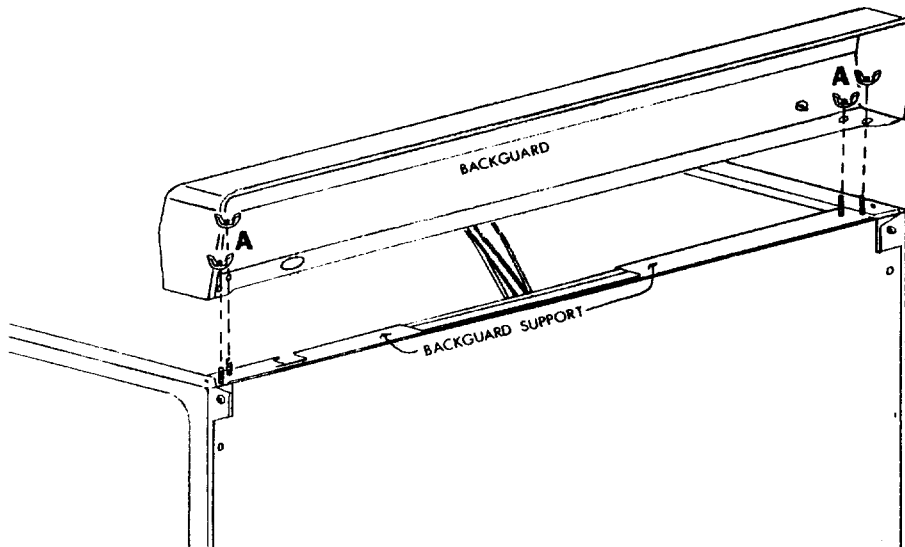

INSTALLATION STEPS

Electrical connections to the range

Use only a 3-conductor, or if required, a 4-conductor range cord. The range power-supply cord used must be rated **250 Volts 40 Amperes** and marked for use with ranges. The range power-supply cord must have open end spade lugs with upturned ends or closed loop terminals.

NOTE: A 4-conductor cord is to be used only when the appliance is installed in a mobile home or where local codes do not permit grounding through the neutral.

TO MAKE 3-CONDUCTOR CONNECTION:

1. Remove screws holding the terminal block cover plate located on the outer back of the range.
2. Insert range cable or connector through opening below terminal block.
3. Connect the cord strain relief to the power supply cord which must be securely attached to the cord set.
4. Connect the neutral (center) supply lead to the center connection on the terminal block using the hex nut provided.
5. Connect the (2) outside supply leads to the corresponding outside terminals using the hex nuts provided.

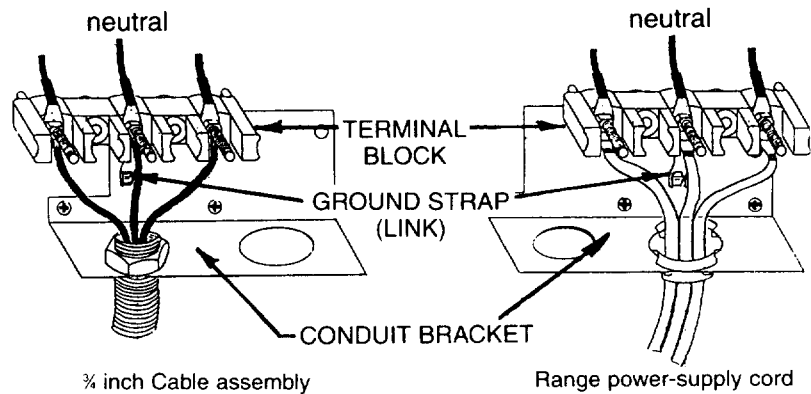

NOTE: Re-locate the conduit bracket for the selected electrical connection, cord or cable, center the conduit bracket below the terminal block. Secure with (3) metal screws to range rear wall.

Special grounding instructions for 4-wire systems

WARNING: Frame grounded to neutral of appliance through a link. If used in a **MOBILE HOME** or if **LOCAL CODES** do not permit grounding through the neutral:

1. Remove the 3-conductor cord (if provided).
2. Cut the ground strap link between the terminal block and the secured end of the link.
3. Using the upturned ends of the ground link and green ground screw from the secured end, attach the ground lead to the unit in accordance with local codes.
4. Connect neutral terminal or lead to the branch circuit neutral in usual manner. (If the appliance is to be connected by means of a cord kit, use a 4-conductor cord for this purpose.)

INSTALLATION STEPS

Anti-tip bracket installation

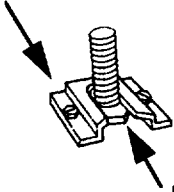
	<p style="text-align: center;">⚠ WARNING</p> <p style="text-align: center;">Tip Over Hazard</p> <p>A child or adult can tip the range and be killed. Connect anti-tip bracket to rear range foot. Reconnect the anti-tip bracket, if the range is moved. See the installation instructions for details.</p> <p>Failure to follow these instructions can result in death or serious burns to children and adults.</p>
<p>Anti-Tip Bracket</p>  <p>Range Foot</p>	<p>Making sure the anti-tip bracket is installed:</p> <ul style="list-style-type: none">• Slide range forward.• Look for the anti-tip bracket securely attached to floor.• Slide range back so rear range foot is under anti-tip bracket.

NOTICE: Parts supplied are for installation in wood floors. If mounting in wood is not possible, consult your local hardware store to purchase anchoring hardware needed to fasten the anchor bracket to your type of floor. Contact a qualified floor covering installer for the best procedure for drilling mounting holes through your type floor covering.

Use the anti-tip bracket template/instruction sheet provided to install the anti-tip bracket. **Anti-tip bracket must be anchored securely to the sub floor.** Depending on the thickness of your flooring, longer screws may be needed to anchor the bracket to the sub floor. Longer screws are available from your local hardware store.

Operating position

Before moving range across floor, check that range is still on cardboard shipping base to protect floor covering.

1. Remove cardboard shipping base from under range. Use channel lock pliers to unscrew rear leg levelers approximately 1/2" so that the rear leg levelers will slide in under the anchor bracket.

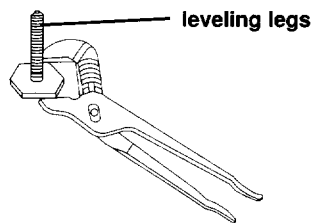

2. Carefully move range into final operating position. Check that rear leveling leg is engaged in anti-tip bracket.

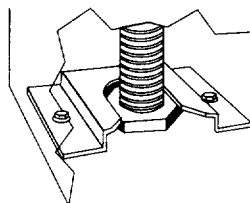

3. If installing the range in a mobile home, you MUST secure the range to the floor. Any method of securing the range is adequate as long as it conforms to the standards in the "Mobile home installation" instructions, Page 17.

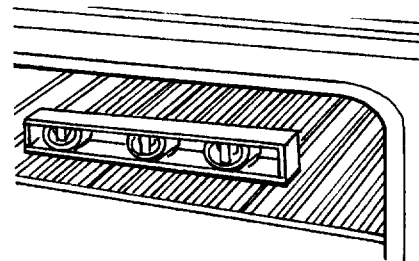

4. Place rack in oven. Place level on rack, first side to side; then front to back.

If range is not level, pull range forward until rear leveling leg is removed from the anti-tip bracket.

Use channel lock pliers to adjust leveling legs up or down until range is level. Push range back into position. Check that rear leveling leg is engaged in anti-tip bracket.

Note: Oven must be level for satisfactory baking conditions.

BEFORE YOU CALL FOR SERVICE

Before you call for service, review this list. It may save you time and expense. This list includes common occurrences that are not the result of defective workmanship or materials in the appliance.

Find your problem here

Possible cause

OVEN AND SURFACE UNITS WILL NOT WORK AT ALL.

The plug on the range is not properly plugged into the electrical outlet. **BEFORE CHECKING PLUG, DISCONNECT THE RANGE POWER SUPPLY AT THE HOUSEHOLD DISTRIBUTION PANEL BY REMOVING THE FUSE OR SWITCHING OFF THE CIRCUIT BREAKER.**

The circuit breaker in your home has been tripped or a fuse has been blown.

OVEN WILL NOT WORK.

The Oven Control is not properly set. See Page 7.

SURFACE UNITS WILL NOT WORK

The Surface Unit Controls are not properly set. Push in and turn to the desired setting.

The surface units are not plugged in solidly.

The drip pans are not set securely in the cooktop.

OVEN TEMPERATURE TOO HOT OR TOO COLD

Oven Thermostat Control operation in the Broil mode. Turn Oven Control to "OFF" and reset Oven Control rotating from "OFF" to the desired temperature.

BAKE ELEMENT CYCLES OFF AND ON.

This is normal for the bake element to cycle as the oven temperature rises above and falls below the set temperature.

SMOKE OR ODOR ON INITIAL OVEN OPERATION.

This is normal during the first few times the oven is used.

FOOD DOES NOT BROIL PROPERLY.

Oven Thermostat Control not set properly. See Broiling Section Page 11.

Improper rack position. See Broiling Section Page 11.

Improper cookware being used.

Improper use of aluminum foil.

FOOD DOES NOT BAKE EVENLY.

Oven Thermostat Control operation in the Broil mode. Turn Oven Control to "OFF" and reset Oven Control rotating from "OFF" to the desired temperature.

Wrong oven rack location being used.

Incorrect cookware or improper size cookware is being used. See Pan Placement Page 9.

Vent tube obstructed. Clear vent opening located beneath one of the rear surface elements.

OVEN LIGHT DOES NOT WORK.

The oven light bulb is loose or defective. Tighten or replace. See Page 12.

The oven light switch is not "ON".

Requesting Assistance or Service

To avoid unnecessary service calls, please check "Before you call for Service" on Pages 24. It may save you the cost of a service call. If you still need help, follow the instructions below.

If you need Assistance or Service

Call the Consumer Assistance Center



toll free at 1-800-253-1301.

Our consultants are available to assist you.

When calling:

Please know the purchase date, and the complete model and serial number of your appliance (see page 4). This information will help us better respond to your request.

Our consultants provide assistance with:

- Features and specifications on our full line of appliances.
- Installation information.
- Use and maintenance procedures.

- Accessory and repair parts sales
- Do-it-yourself repair help
- Specialized customer assistance (Spanish speaking, hearing impaired, limited vision, etc.)
- Referrals to local dealers, service companies, and repair parts distributors

Our service technicians are trained to fulfill the product warranty and provide after-warranty service, anywhere in the United States.

To locate the authorized service company in your area, you can also look in your telephone directory Yellow Pages.

If you need Replacement Parts

If you need to order replacement parts, we recommend that you only use our factory authorized parts. Our replacement parts will fit right and work right, because they are made to the same exacting specifications used to build our new appliances.

To locate replacement parts in your area, call our Consumer Assistance Center telephone number or your nearest authorized service center.

For further Assistance

If you need further assistance, you can write to us with any questions or concerns at:

Consumer Assistance Center
c/o Correspondence Dept.
2000 North M-63
Benton Harbor, MI 49022-2692

Please include a daytime phone number in your correspondence.

If the dealer, authorized servicer, and we have failed to resolve your problem, you can contact the Major Appliance Consumer Action Program (MACAP). MACAP is a group of independent consumer experts that voice consumer views at the highest levels of the major appliance industry. MACAP will in turn inform us of your action.

Major Appliance Consumer Action Program
20 North Wacker Drive
Chicago, IL 60606

WARRANTY - Electric Range

LENGTH OF WARRANTY	WE WILL PAY FOR
FULL ONE-YEAR WARRANTY FROM DATE OF PURCHASE	Replacement parts and repair labor to correct defects in materials or workmanship. Service must be provided by an authorized service company.
WE WILL NOT PAY FOR	
<p>A. Service calls to:</p> <ol style="list-style-type: none"> 1. Correct the installation of your range. 2. Instruct you how to use your range. 3. Replace house fuses or correct house wiring. 4. Replace owner-accessible light bulbs. <p>B. Pickup and delivery. Your range is designed to be repaired in the home.</p> <p>C. Damage to your range caused by accident, misuse, fire, flood, acts of God, or use of products not mentioned in this manual.</p> <p>D. Repairs to parts or systems caused by unauthorized modifications made to the appliance.</p> <p>E. Repairs when your range is used in other than normal, single-family household use.</p>	

WHIRLPOOL CORPORATION SHALL NOT BE LIABLE FOR INCIDENTAL OR CONSEQUENTIAL DAMAGES.

Some states do not allow the exclusion or limitation of incidental or consequential damages, so this exclusion or limitation may not apply to you. This warranty gives you specific legal rights, and you may also have other rights which vary from state to state.

Outside the United States, a different warranty may apply. For details, please contact your authorized dealer.

If you need service, first see the "Before you call for Service" section of this book. After checking "Before you call for Service," additional help can be found by checking the "Requesting Assistance or Service" section, or by calling the Whirlpool Corporation Consumer Assistance Center telephone number, **1-800-253-1301**, from anywhere in the U.S.A.